

CHELSEA® 340 SERIES

One Speed Forward and Reverse Mechanical PTO

The Chelsea 340 Series PTO is another example of why Chelsea PTO technology is the best in the business. This economical workhorse features a cast iron housing and heavy duty ball bearing on the output shaft, giving it a high torque rating and long service life. Chelsea was the first to provide you with an Air shifted forward and reverse speed PTO. Its flexible Air shift design allows you to mount the air shift cylinder in the best position for maximum clearance. Torque ratings up to 200 lbs-ft make this one versatile PTO. Take advantage of years of Chelsea PTO technology to increase performance and lower costs.

Applications:

- Oil Fields
- Logging

Product Features and Benefits:

- Speed – Single low-speed forward and reverse.
- Backlash – Removable cover plate for adjusting.
- Shift Options – Air and Lever.
- Input Gears – Cover most applications.
- Mounting – 6-Bolt.
- Confidence – Two Year Warranty.

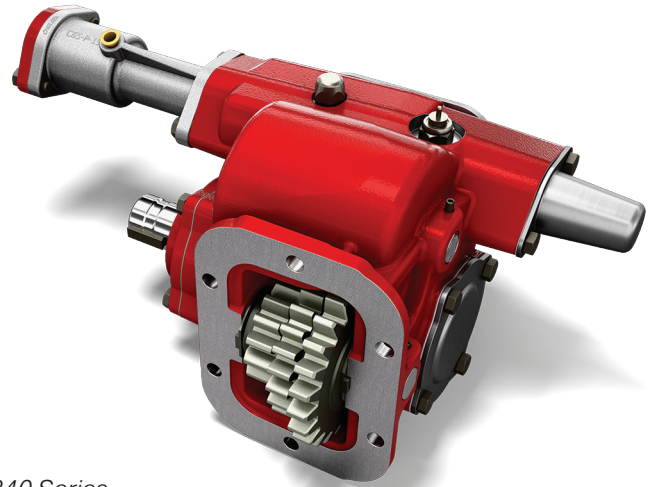

340 Series



340 Series Power Take-Off – Multiple Transmission Options

Model Number Designator & Specifications

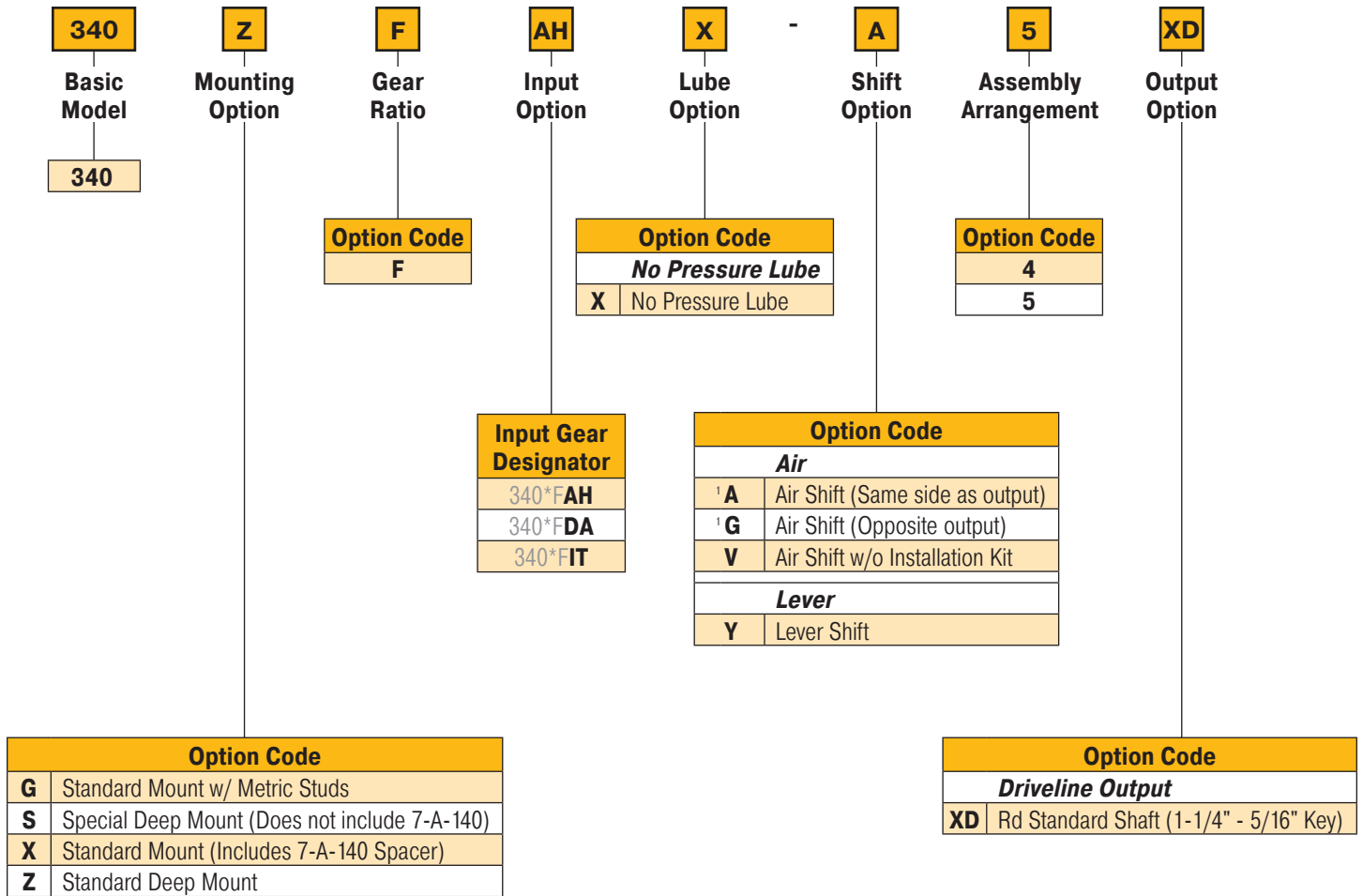

¹ Includes mounting parts.

Specifications Chart		Approximate Weight: 32 lbs. [15 kg]
		340*F
Intermittent Torque Rating lb-ft [N-m]		200 [271]
HP Rating for Intermittent Service		
At 500 RPM of Output Shaft HP [kW]		19 [14]
At 1000 RPM of Output Shaft HP [kW]		38 [28]

340 Series Power Take-Off – Multiple Transmission Options

Dimensions – For PTO output information see application catalog

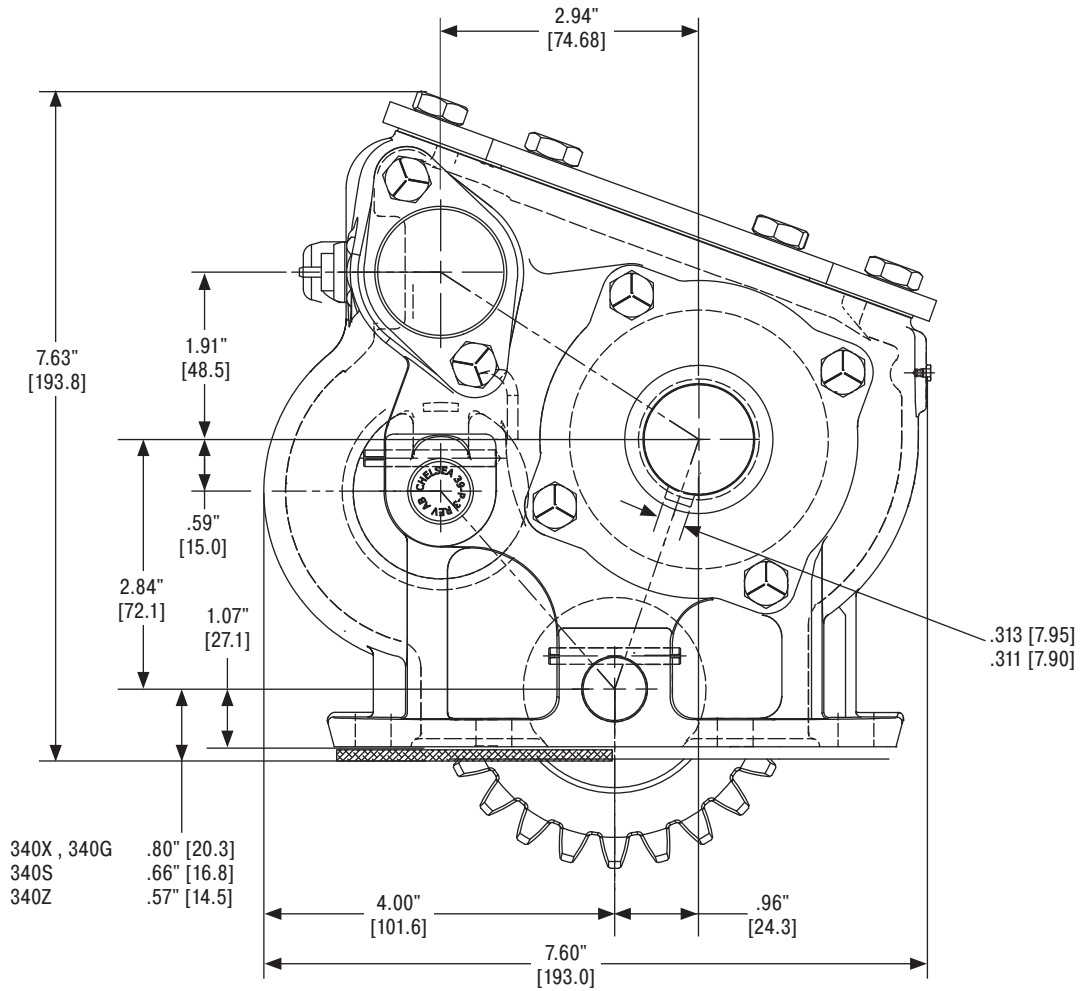

Parker Hannifin Corporation
Chelsea Products Division
 8225 Hacks Cross Road
 Olive Branch, MS 38654 USA
 phone 1-888-PH4-TRUK (1-888-744-8785)
 chd_support@support.parker.com
 www.parker.com/chelsea

HY25-0106-B1/US November 2025

© 2025 Parker Hannifin Corporation

